

See discussions, stats, and author profiles for this publication at: <https://www.researchgate.net/publication/236591742>

# Invasive Carassius Carp in Georgia: Current state of knowledge and future perspectives

ARTICLE *in* CURRENT ZOOLOGY · DECEMBER 2013

Impact Factor: 1.59 · DOI: 10.1093/czoolo/59.6.732

---

CITATIONS

2

---

READS

37

3 AUTHORS, INCLUDING:



[Bella Japoshvili](#)

Ilia State University

14 PUBLICATIONS 19 CITATIONS

[SEE PROFILE](#)



[Levan Mumladze](#)

Ilia State University

31 PUBLICATIONS 135 CITATIONS

[SEE PROFILE](#)

## Invasive *Carassius* carp in Georgia: Current state of knowledge and future perspectives

Bella JAPOSHVILI<sup>1</sup>, Levan MUMLADZE<sup>2\*</sup>, Fahrettin KÜÇÜK<sup>3</sup>

<sup>1</sup>Institute of Zoology, Ilia State University, Kakutsa Cholokashvili st. 3/4, 0162 Tbilisi, Georgia

<sup>2</sup>Institute of Ecology, Ilia State University, Kakutsa Cholokashvili st. 3/4, 0162 Tbilisi, Georgia and Invertebrate Research Centre (IRC), Tbilisi, Georgia. Agladze st. 26, 0119

<sup>3</sup>Süleyman Demirel University, Eğirdir Fisheries Faculty, 32500, Eğirdir, Isparta, Turkey

**Abstract** In Georgia, crucian carp *Carassius carassius* (Linnaeus, 1758) was known from only one locality after Kessler's record (1877–1878) with no new findings until 1985. Since then *C. carassius* rapidly and simultaneously invaded almost all water bodies of Georgia. In 2004, it was for the first time noted that this invasive *Carassius* sp. could not be a *C. Carassius*, but was a form of *Carassius gibelio* (Bloch, 1792). However no further data is available about this invasive species in Georgia. The aim of the present study was to investigate taxonomic status of *Carassius* sp. in Georgia using mtDNA phylogenetic analyses and morphometric study of truss network system. Genetic analysis revealed that invasive *Carassius* sp. is closely related to the *C. gibelio* from Turkey and other countries. In contrast, morphometrically *Carassius* sp. from Georgia can be easily differentiated from those of Turkey indicating high intraspecific variability. This is the first time discussion on the current knowledge of the present distribution of invasive carp in Georgia with identifying current problems and future research directions needed [*Current Zoology* 59 (6): 732–739, 2013].

**Keywords** *Carassius* carp, Genetic, Georgia, Invasion, Morphometric

*Carassius* carps have been a popular freshwater fish from ancient times as a valuable food source and as the basis of sport fisheries. The goldfish, *Carassius auratus* (Linnaeus, 1758) is also likely the most popular aquarium fish species in the world. Because of its popularity and ability to deal with a wide range of aquatic conditions, species of the genus *Carassius* have also become one of the most successful invader fish species of the last century, which makes it a group for ecological concern as well. However because of high morphological variation and genetic complexity, species level taxonomy for this group can be controversial (Vasilieva and Vasiliev, 2000; Goryunova and Skakun, 2002; Iguchi et al., 2003; Toth et al., 2005; Kottelat and Freyhof 2007; Jung et al., 2009; Sakai et al., 2011; Kalous et al., 2012).

In Georgian waters *Carassius* sp. was first recorded by Kessler 1877–1878 (cited by Elanidze, 1983) from Lake Paliastomi (western Georgia) and attributed as crucian carp (*Carassius carassius* (Linnaeus, 1758)). This reference has been widely cited (Kamenskii, 1899;

Satunin, 1914<sup>1</sup>; Sadovskii, 1930; Burjanadze, 1940; Barach, 1941; Berg, 1949; Sharvashidze, 1960; Elanidze, 1983) for the occurrence in the waters of western Georgia (namely Lake Paliastomi). No further finds appeared from inland waters of Georgia (Elanidze, 1983) until 1985 when the existence of *C. carassius* was reported again in Lake Paliastomi (Daraselia, 1985). This author mentioned that crucian carp was rare in Lake Paliastomi and suspected that the population may have originated from unintentional release with the fry of common carp (*Cyprinus carpio* L.). In the beginning of 21st century the report of Wetland International mentioned that the coastal waters of Georgia harbor *C. auratus gibelio* and *C. carassius* (Goradze et al., 2003), without, however, any relevant literature citation. The next published data about *Carassius* species appeared in 2004 (Japoshvili et al., 2004) when *Carassius* sp. collected from Lake Paravani (south-east Georgia) was compared morphologically to *Carassius gibelio* (Bloch, 1792) from Turkey (Lake Eğirdir). The authors did not find significant morphological differences between the populations and

<sup>1</sup> Satunin KA, 1914. Freshwater fishes on the Caucasian Black sea shore. Proceedings of Conference of Caucasian Black Sea shore III (In Russian).

Received Mar. 30, 2013; accepted Apr. 24, 2013.

\* Corresponding author. E-mail: levan.mumladze@iliauni.edu.ge

© 2013 *Current Zoology*

it was suggested that the *Carassius* carp species from the Lake Paravani should be considered as a variant of *C. gibelio* complex rather than *C. carassius*. However, the most recent fish check-list of Georgia (Ninua and Japoshvili, 2008) and the newly published “Fishes of Georgia” (Nunua et al., 2013) does not address these taxonomic ambiguities but report the wide distribution of the *Carassius* sp. within Georgia.

Apart from the references described above, there have been no other published data about *Carassius* carp species in Georgia and it is unclear which *Carassius* species occur in Georgian inland waters and when they invaded. Considering that species invasions can be influential factor in environmental changes (Kolar and Lodge, 2001; Gozlan et al., 2010 and references therein), there is an urgent need to study biological peculiarities of the *Carassius* carp species and their impact on the freshwater ecosystems in Georgia.

In the present work based on the comparative genetic and morphometric study of samples collected in Georgia and Turkey it was attempted to clarify the taxonomic status of the *Carassius* carp in Georgian waters. There were also summarized and discussed all available information about the *Carassius* carp in Georgia which could be base of new research and management strategy.

## 1 Materials and Methods

### 1.1 Data collection

Gibel carp *C. gibelio* collected from Egirdir Lake (Turkey) were used for genetic and morphometric comparisons with Georgian *Carassius* samples. In the spring 2011, 37 specimens of *Carassius* from Jinvali and Jandara reservoirs (Georgia, 19 specimens) and from Egirdir Lake (Turkey 18 specimens) were collected (Fig. 1; Table 1). All of them were used for morphological studies whereas eight specimens (four from Egirdir Lake, and two from each of the two lakes from Georgia) were subjected to DNA analysis.

### 1.2 Analysis of mtDNA

To clarify the taxonomic status of *Carassius* sp. from Georgia, part of the mtDNA control region – D-loop (CR hereafter) was analyzed. Total cellular DNA was extracted from dorsal fin tissue using QIAGEN® QIAamp DNA Mini Kit followed by a slightly modified standard protocol (QIAGEN® 2007). Partial mtDNA CR was amplified and sequenced for four specimens of gibel carp from Turkey (CGT1-4) and four specimens of *Carassius* sp. from Georgia (CJI1-2 from Jinvali Lake and CJA1-2 from Jandara Lake) with primers CarU32 (5'-CCAAAGCCAGAATTCTAAAC-3') and CarL509 (5'-GCATGTGGGGTAATGA-3') (Vetesnik et al., 2007).

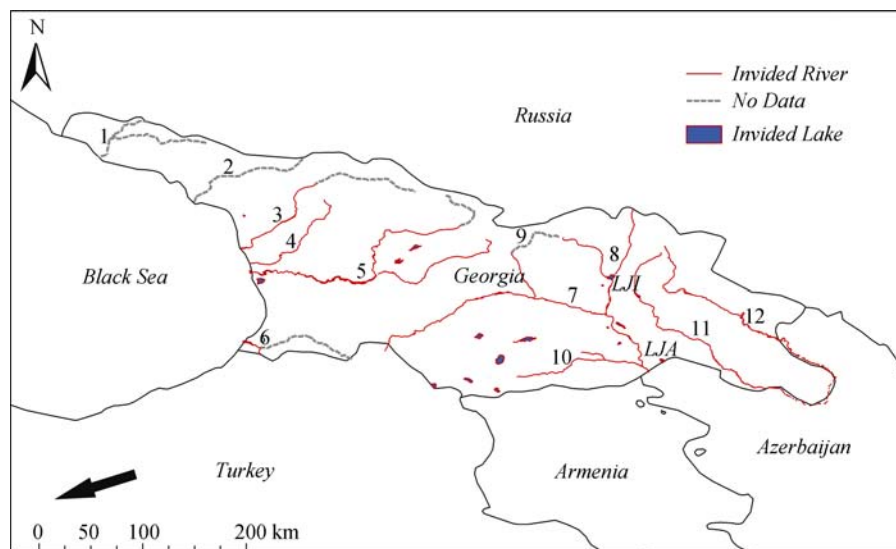

**Fig. 1** Major river and lake systems of Georgia

Red lines indicate rivers from where *Carassius* carp is known. All blue shapes with red outlines represent major lakes and artificial reservoirs which also harbor *Carassius* carp. Dashed lines indicate parts of the major rivers with absence of relevant information. Abbreviations stand for LJI – Jinvali Lake, LJA – Jandara Lake (our Georgian sampling localities). Numbers indicate rivers: 1 - Bzyb; 2 - Kodori; 3 - Enguri; 4 - Khobi; 5 - Rioni and Kvirila (tributary); 6 - Chorokhi and Acharistskali (tributary); 7 - Mtkvari and its tributaries (8 - Aragvi; 9 - Liakhvi; 10 - Khrami); 11 - Iori; 12 - Alazani. The arrow in the left-bottom corner indicates the directions where Egirdir Lake (our Turkish sampling point) is situated.

**Table 1** Coordinates and altitude of major lakes harboring *Carassius carp* in Georgia

Lake	Longitude	Latitude	Altitude
Kartsakhi	43.2326	41.2163	1799
Basaleti	44.6779	42.0394	881
Jandara	45.2100	41.4343	294
Shaori	43.0672	42.4133	1131
Sioni	44.9843	42.0116	1043
Khnachali	43.5327	41.2644	1931
Kumisi	44.8394	41.5845	472
Paliastomi	41.7273	42.1219	0
Paravani	43.8042	41.4426	2078
Saghamo	43.7337	41.3070	1999
Tabatskuri	43.6229	41.6477	1992
Tbilisi reservoir	44.8464	41.7443	540
Tsalka	44.0420	41.6202	1503
Bebesiri	41.5835	42.6881	18
Jinvali	44.7704	42.1496	780
Tkibuli reservoir	42.9283	42.2979	523
Lisi	44.7339	41.7450	650

Amplification conditions and temperature profiles were as follows: The denaturation 95°C 1 minute, 32 cycles 94°C 45 second / 50°C 30 second / 72°C 45 second, final extension 72°C for 7 minute. Double stranded sequencing was performed on the automatic sequencer ABI 3130 with the polymerase chain reaction primers, using the Big-Dye Terminator v3.1. DNA sequences were edited using SEQSCAPE v2.5 (Applied Biosystems Inc. Foster City, California, U.S.A.). Derived sequences were deposited in Gen-Bank under accession numbers KC243407 to KC243414.

Obtained sequences were aligned with published sequences for *C. auratus* (CA1 - Vetesnik et al., 2007, GenBank accession number AY940118; CA2 - Komiyama et al., 2009, AB379923), *C. gibelio* (CG1 - Wouters et al., 2012, JN117599; CG2 - GQ985480, unpublished; CG3 - GU138989, unpublished), *C. carassius* (CC1 - Cheng et al., 2012, JQ911695; CC2 and CC3 - Wouters et al., 2012, JN117596 - JN117597) and *C. carpio* (CYC - Yang et al., 2011, JX122531) as an out-group. Gaps were treated as missing data. Neighbor-Joining (NJ), Maximum Parsimony, Maximum Likelihood methods (Nei and Kumar, 2000) and median-joining network (Bandelt et al., 1999) were used to infer phylogenetic relationships assuming differences between transition/transversion rates (Kimura, 1980). To test phylogenetic dendrograms a bootstrap method (Felsenstein, 1985) was applied with 1000 iterations.

Sequence alignment and phylogenetic analysis were performed using programmes MEGA5 (Tamura et al., 2011) and Network 6.4.1.1. (Bandelt et al., 1999).

### 1.3 Morphological comparisons

Univariate and multivariate methods were used to explore the relationship of morphological features between Georgian and Turkish specimens. It is suggested that the specimen/variable ratio in multivariate morphometric analysis should be more than 2:1 to indicate species level differentiation (Pimentel, 1979). As the sample contained only 37 specimens, multivariate analysis of truss network system were chosen which is based on inter-landmark distances (Bookstein et al., 1985). The truss network analysis is a powerful method which allowed lower dimensionality than might be the case for geometric-morphometric methods. Morphometric data were collected by digitizing the left side of all collected specimens and 9 landmarks were placed on each image (Fig. 2) using tpsDig v2 (Rohlf, 2005). Prior to the analysis landmark coordinates was transformed using generalized least squares procrustes superimposition by which all specimens were scaled to unit centroid size. From transformed landmark coordinates 15 linear distance measures were extracted (Fig. 2) which were used in the principal component analysis (PCA). Regression residuals for PCs with eigenvalues exceeding 1 were tested for significance using the parametric *t*-test (Sokal and Rohlf, 1995). Coordinate transformation and statistical analysis were performed using the statistical software SPSS v16 (SPSS Inc., Chicago, IL, USA) and PAST (Hammer et al., 2011).

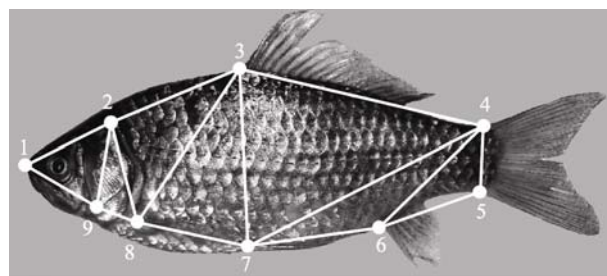

**Fig. 2** Picture of the *Carassius carp* with the 9 anatomical landmarks and 15 distances used in the analysis

The landmarks (numbered points) are: 1 - snout; 2 - dorsal tip of cleithrum; 3 - origin of dorsal fin; 4 - origin of first ray of dorsal caudal fin; 5 - origin of first ray of ventral caudal fin; 6 - anterior insertion of anal fin; 7 - anterior insertion of pelvic fin; 8 - dorsal insertion of pectoral fin; 9 - ventral tip of cleithrum.

## 2 Results

Sequences of 438 bp length mtDNA control region were obtained from eight *Carassius* samples. In total 32

variable sites were detected from which 31 were parsimoniously informative. Concerning only Georgian-Turkish sample, four unique haplotypes were identified, one from Jinvali Lake (Georgia) and one from Egirdir Lake (Turkey) and two from Jandara Lake (Georgia) (Fig. 3).

All phylogenetic analysis methods (including the median-joining network) produced identical results and only the haplotype network and NJ tree are shown with high statistical significance (Fig. 3). Ten unique haplotypes are grouped in 5 well separated haplogroups of which all three *C. carassius* haplotypes - CC1 - from China and CC2, 3 from Sweden - grouped together (Fig. 3) whereas *C. auratus* and *C. gibelio* created diverse haplotype distribution. Samples from Lake Egirdir (CGT1-4) grouped with *C. auratus* from China (CA2) and *C. gibelio* from Russia (CG2). Haplotypes from Lake Jandara (C-JA1, 2) grouped with *C. gibelio* from Sweden (CG1) and China (CG3). Haplotypes from Lake Jinvali produced separate haplogroup which was most close to the *C. auratus* from Czech (Fig. 3). In general all Georgian-Turkish samples with GenBank data produced one complex *Carassius auratus-gibelio* clade whereas *C. carassius* samples were united in a different and well separated clade. It must be noted here that our result of mtDNA comparison does not support the existence of significant differences between two *C. auratus* and *C. gibelio* forms as a separate species.

All collected specimens were females. PCA based on 15 size-adjusted inter-landmark distances for 37 specimens produced five PCs with eigenvalue >1. These four components explained 79% of total variation. Two independent sample t-test revealed significant differences between Georgian and Turkish samples only for residuals of second and third PCs at the 0.05 level (Table 2). These two components most successfully (but not perfectly) separated between Georgian and Turkish sample (Fig. 4). First PC did not differentiate significantly Georgian and Turkish samples and represented an overall body size (perimeter) indicator as highest loadings were on the outer inter-landmark distances. The strongest and significant differences were found at PC2 describing body height (highest loadings were for distance d2-8 and d3-8; Table 2; Fig. 2), indicating that fishes from Turkey tended to be taller at gill cover. The third PC seems to be associated with caudal shape and body length. Georgian sampled fishes tended to have elongated head and shortened caudal region compared to fishes from Turkish sample (distances with highest loadings: d2-3, d4-5, d5-6, d6-4; Table 2; Fig. 2) along the third PC.

### 3 Discussion

#### 3.1 Characterization of Georgian *Carassius* carp

Fishes are phenotypically among the most variable animals at the intraspecific level (e.g. [Ihssen et al., 1981](#);

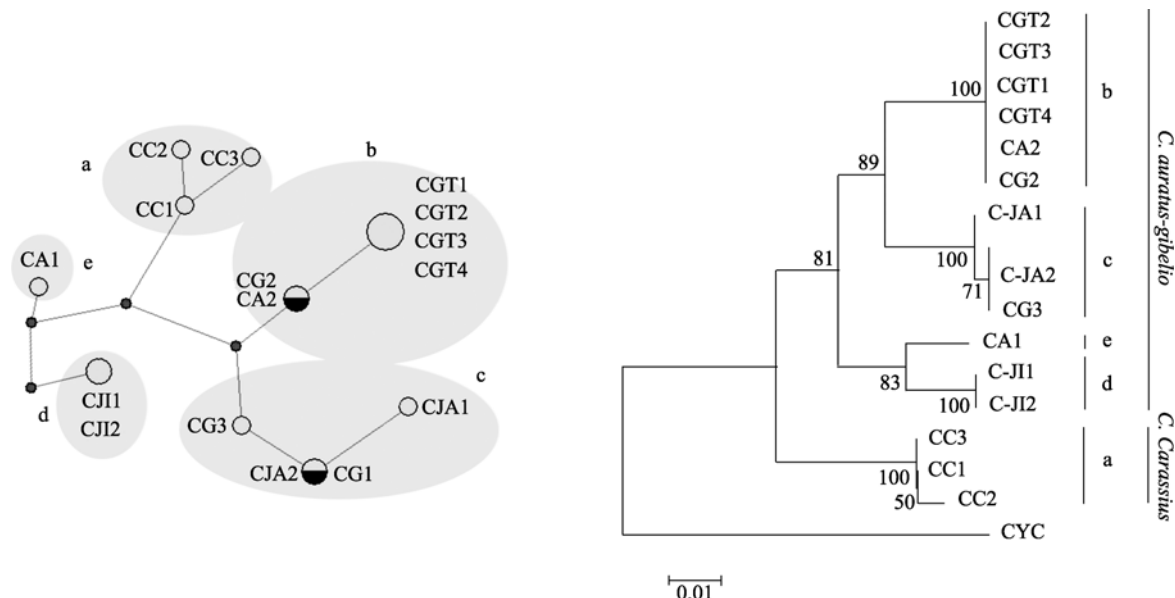

**Fig. 3** Phylogenetic trees of analyzed *Carassius* sample

Left panel - Median joining network showing the relationships between haplotypes. Node sizes are proportional to haplotype frequencies in the dataset. Line lengths between nodes are proportional to nucleotide changes; Right panel - NJ bootstrap consensus phylogenetic tree (inferred from 1000 replicates). Supporting bootstrap values are shown next to the branches. Branch length indicates the number of substitution according to scale bar. Ten unique haplotypes are grouped in five haplogroups a,b,c,d,e which are relevant to the groups in the median joining tree on the left panel. For further explanation see the text.

Hinder and Jonsson, 1993; Peres-Neto and Magnan, 2004; Grunbaum et al., 2007), showing particularly much environmentally induced variation (Hubbs, 1926; Lindsey, 1988; Lovell, 1998). Species of the genus *Carassius* (especially *C. auratus*) are characterized by incredible intraspecific phenotypic variability and high

**Table 2 Results of PCA of interlandmark distances**

Variable	PC1	PC2	PC3	PC4	PC5
d1-2	0.82	-0.31	-0.03	-0.23	0.13
d2-3	0.01	0.44	<b>-0.67</b>	0.29	-0.04
d3-4	-0.08	-0.47	0.58	0.01	0.36
d4-5	0.11	0.29	<b>0.62</b>	0.08	-0.39
d5-6	0.42	0.27	<b>0.62</b>	0.16	-0.09
d6-7	-0.90	0.15	-0.18	-0.06	0.00
d7-8	0.55	-0.53	-0.38	0.31	-0.04
d8-9	-0.10	0.56	-0.03	-0.63	0.38
d9-1	0.76	-0.22	-0.10	-0.12	-0.09
d2-9	0.76	0.16	-0.06	-0.27	0.08
d2-8	0.22	<b>0.77</b>	0.11	-0.37	-0.22
d3-7	0.60	0.32	-0.29	0.18	0.56
d3-8	0.40	<b>0.60</b>	-0.44	0.31	-0.19
d6-4	0.56	0.37	<b>0.60</b>	0.36	0.10
d4-7	-0.50	0.43	0.23	0.46	0.40
<i>F</i>	2.4	8.2	0.05	4.7	0.04
<i>df</i>	35	35	35	35	35
<i>P</i>	0.06	<b>0.001</b>	<b>0.04</b>	0.15	0.19

Each row represents distances and its contribution (loadings) on each of five PC (with eigenvalues exceeding unit). Last three rows represent the results of *t*-tests for each PCs were *F* – differences, *df* – degrees of freedom, *P* – two tailed significance value.

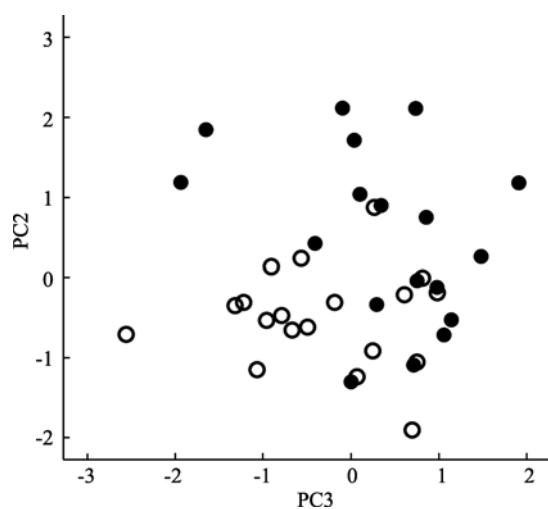

**Fig. 4 Regression residuals of first vs. second PCs are shown for 15 distance variables (truss system)**

Open circles - *Carassius sp.* from Georgia; Filled circles – *C. gibelio* from Turkey.

interspecific similarity (Wheeler, 2000; Kottelat and Freyhof, 2007). It is well documented that the environmental conditions has a significant influence on phenotypic variation in crucian carps (Bronmark and Miner, 1992; Nilsson et al., 1995; Holopainen et al., 1997), often making it difficult to identify of *Carassius* species (Iguchi et al., 2003; Jung et al., 2009). Our results indicate that the *C. carassius* is not as common in Georgian inland waters as previously thought. Comparison of meristic characters and the molecular genetic analysis did not support the existence of *C. carassius* in Paravani Lake (Japoshvili, 2004). Jandara and Jinvali Lakes harbors lineages more closely related to *C. gibelio* than to *C. carassius*. Morphometric analysis using the truss system showed that populations of *Carassius sp.* from Georgia were significantly differentiated from Turkish gibel carp population. The methods of morphometric study (either geometric morphometric or truss network analysis) can be used to distinguish between intraspecific stock/populations or even to reveal interpopulation differentiation (Dwivedi and Dubey, 2012). Taken together, our genetic and morphometric results show that the most successful invasive fish in Georgian inland waters most probably is a gibel carp – *C. gibelio*. However additional study of larger sample and reproductive strategy is needed to make a comprehensive picture of the distribution and identity of *Carassius* carp in Georgia as the *C. auratus-gibelio* system is very complex system itself (Takada et al., 2010; Kalous et al., 2012). The true identity of Kessler's (1877–1878 cited in Elanidze (1983) or Daraselia's (1985) specimens also remains doubtful. Further research in Lake Paliastomi is needed to answer this question.

### 3.2 Invasion history, current distribution and implications for future strategies

There is no data available about the introduction pathways of gibel carp in Georgia. One of the most likely method of introduction were the unintentional releases with the fry of common carp (or other cyprinids). After its initial establishment, people started to introduce it in other water bodies intentionally (which is still continuing in some areas in order to either support existing *Carassius* population or establish new ones). There is a common belief among the public and conservation managers that gibel carp has been spread by birds that carry their eggs from one place to another (e.g. NACRES, 2000). This way of dispersion is possible although there is no evidence to support this. There is no available information about the exact date when gibel carp were initially introduced. It is highly likely



that Daraselia (1985) reported one of the first newly established gibel carp populations but soon after gibel carp quickly spread to all accessible water bodies in Georgia. Currently gibel carp can be found in most lakes and rivers of Georgia (personal observation, Fig. 1) and is one of the most abundant and frequently caught species in sport fisheries.

Invasive species are considered a primary driver for loss of native biodiversity (for the review see Gozlan et al., 2010). However this may not be universally true (Didham et al., 2005). There is evidence that actual costs to native species and ecological functions will depend on the characteristics of the host system and invader (Fraser and Adams, 1997; Davis, 2009). A major challenge may be detection of the invader and early signs of the effects on the ecosystem. Some early signs of the effects of an invasive species altering a system include interspecific interactions with native species such as competition for food and space, hybridization, habitat modification or distribution of new disease (for review see Gozlan et al., 2010). Invasive species are not the only factor currently affecting aquatic ecosystems in Georgia. Uncontrolled deforestation, water and air pollution and illegal harvest are some of the other forces occurring in Georgian waters (Fourth National Report to the United Nations Convention on Biological Diversity: Georgia, 2010 - FNPG). To date, there have been no investigations on invader ecology or the risks they pose to our aquatic systems (FNPG, 2010). For example, the Georgian National Biodiversity Strategies and Action Plan (NBSAP-Georgia, 2005) does not discuss the necessity of developing legislative basis to deal with invasive species nor developing of control mechanisms to reduce the negative effects of different stocking activities. It can be argued that regular monitoring programs are needed within the national legislative framework before more harm occurs (which is obligate for Georgia as a partner country of CBD – Conservation Biological Diversity). To overcome the problems associated with the invasion of gibel carp, it is suggested to conduct four initial actions: 1) catalogued and organize the existing information on the distribution of indigenous and invasive fish populations; 2) conduct surveys to determine the current distribution of gibel carp in Georgian waters; 3) select several model watersheds to study the ecological interactions between native and invasive species to better determine risks and potential mitigation actions; and 4), either in combination with (3) or separately, select a subset of water bodies as index sites to monitor for biodiversity and other measures of sys-

tem integrity (Parker et al., 1999). Since developing countries, like Georgia, may not have the sufficient expertise and resources to support such an effort, (Gozlan et al., 2010), it may be important to receive international assistance in the form of expertise and financial support (Gaygusuz et al., 2007; Leonardos et al., 2008a,b; Economidis et al., 2000; Zenetos et al., 2009; Koutrakis et al., 2007; Perdikaris et al., 2012).

**Acknowledgements** We would like to thank Dr Jouko Sarvala, Dr Christopher Peery and Dr Elias Dana who kindly improve writing language and commented the draft of the manuscript. Special thank to Prof. Gursel Karaca for providing laboratory facilities. The study was supported by the Scientific and Technological Research Council of Turkey (TÜBİTAK).

## References

- Bandelt HJ, Forster P, Rohlf A, 1999. Median-joining networks to inferring intraspecific phylogenies. *Mol. Biol. Evol.* 16: 37–38.
- Barach GP, 1941. Fresh Water Fishes of Georgia. Tbilisi: Metsniereba (In Russian).
- Berg LC, 1949. Freshwater Fishes of USSR and Adjacent Countries. Moscow: Academy of Science of USSR (In Russian).
- Bookstein FL, Chernoff B, Elder RL, Humphries JM, Smith GR, et al., 1985. Morphometrics in Evolutionary Biology. Philadelphia: The Academy of Natural Sciences of Philadelphia.
- Bronmark C, Miner JG, 1992. Predator-induced phenotypical change in body morphology in crucian carp. *Science* 258: 1348–1350.
- Burjanadze M, 1940. Identification Key of Georgian Freshwater Fishes. Tbilisi: Metsniereba (In Georgian).
- Cheng L, Liang LQ, Sun XW, 2012. The complete mitochondrial genome of the crucian carp *Carassius carassius* (Cypriniformes, Cyprinidae). *Mitochondr. DNA* 23: 350–351.
- Daraselia TG, 1985. Existence of *Carassius carassius* in inland waters of Georgia. In: Kurashvili B ed. Proceedings of the Conference of Young Scientists. Tbilisi: Institute of Zoology, 12–14 (In Russian).
- Davis MA, 2009. *Invasion Biology*. Oxford: Oxford University Press.
- Didham RK, Tylanakis JM, Hutchison MA, Ewers RM, Gemmill NJ, 2005. Are invasive species the drivers of ecological change? *Trends Ecol. Evol.* 20: 470–474.
- Dwivedi AK, Dubey VK, 2012. Advancements in morphometric differentiation: A review on stock identification among fish populations. *Rev. Fish Biol. Fish.* 23: 23–39.
- Economidis PS, Dimitriou E, Pagoni R, Michaloudi E, Natsis L, 2000. Introduced and translocated fish species in the inland waters of Greece. *Fisheries Manag. Ecol.* 7: 239–250.
- Elanidze PF, 1983. Fishes of Lakes and Rivers of Georgia. Tbilisi: Metsniereba (In Russian).
- Felsenstein J, 1985. Confidence limits on phylogenies: An approach using the bootstrap. *Evolution* 39: 783–791
- FNPG 2010 Fourth National Report to the United Nations Convention on Biological Diversity: Georgia. Tbilisi. <http://www.cbd>.

- int/countries/?country=ge; Retrieved 12.2012.
- Fraser D, Adams CE, 1997. A crucian carp *Carassius carassius* (L.) in Loch Rannoch, Scotland: Further evidence of the threat posed to unique fish communities by introduction of alien fish species. *Aquatic Conser: Mar. Freshw. Ecosyst.* 7: 323–326.
- Gaygusuz O, Tarkan AS, Gaygusuz CG, 2007. Changes in the fish community of the Omerli reservoir (Turkey) following the introduction of non-native gibel carp [*C. gibelio* (Bloch, 1782)] and other human impacts. *Aquat. Invas.* 2: 117–120.
- Goradze R, Machutadze I, Goradze I, 2003. Georgia. In: Marushevsky G ed. *Directory of Azov-Black Sea Coastal Wetlands*. Kyiv: Wetlands International, 235.
- Goryunova AI, Skakun D, 2002. Biological characterization on crucian carps. *Tethys Aqua. Zool. Res.* 1: 33–48.
- Gozlan RE, Britton JR, Cowx I, Copp GH, 2010. Current knowledge on non-native freshwater fish introductions. *J. Fish Biol.* 76: 751–786.
- Grunbaum T, Cloutier R, Mabee PM, Francois NR, 2007. Early developmental plasticity and integrative responses in Arctic charr *Salvinus alpinus*: Effects of water velocity on body size and shape. *Journal of Exp. Zool.* 308: 396–408.
- Hammer O, Harper DAT, Ryan PD, 2011. PAST: Paleontological Statistics software package for education and data analysis. *Paleontol. Electron.* 4: 1–9.
- Hinder I, Jonsson B, 1993. Ecological polymorphism in Arctic charr. *Biol. J. Linn. Soc.* 48: 63–74.
- Holopainen IJ, Aho J, Vornanen M, Huuskonen H, 1997. Phenotypic plasticity and predator effects on morphology and physiology of crucian carp in nature and in the laboratory. *J. Fish Biol.* 50: 781–798.
- Hubbs CL, 1926. The structural consequences of modifications of the developmental rate in fishes, considered in reference to certain problems of evolution. *Am. Nat.* 60: 57–81.
- Iguchi K, Yamamoto G, Matsubara N, Nishida M, 2003. Morphological and genetic analysis of fish of a *Carassius* complex (Cyprinidae) in Lake Kasumigaura with reference to the taxonomic status of two all-female triploid morphs. *Biol. J. Linn. Soc.* 79: 351–357.
- Ihssen PE, Booke HE, Casselman JM, McGlade JM, Payne NR et al., 1981. Stock identification: materials and methods. *Can. J. Fish. Aquat. Sci.* 38: 1838–1855.
- Jung J, Kyo HS, Lee E, Kim W, 2009. Mitochondrial genetic variations in fishes of the genus *Carassius* from South Korea: Proximity to northern China rather than Japanese Islands? *Hydrobiologia* 635: 95–105.
- Japoshvili B, Ertan O, Diler O, 2004. A study of morpho-ecological characters of *Carassius auratus* L. and *Carassius carassius* (L). *Proc. Inst. Zool.* 12: 280–283.
- Kalous L, Bohlen J, Rylková K, Petrýl M, 2012. Hidden diversity within the Prussian carp and designation of a neotype for *Carassius gibelio* (Teleostei: Cyprinidae). *Ichthyol. Explor. Fres.* 23: 11–18.
- Kamenskii CN, 1899. Carps (Cyprinidae) of Caucasus and Transcaucasia. Tbilisi: Caucasus Natural History Museum (In Russian).
- Komiyama T, Kobayashi H, Tateno Y, Inoko H, Gojobori T et al., 2009. An evolutionary origin and selection process of goldfish. *Gene* 430: 5–11.
- Kimura M, 1980. A simple method for estimating evolutionary rates of base substitutions through comparative studies of nucleotide sequences. *J. Mol. Evol.* 16: 111–120.
- Kolar CS, Lodge DM, 2001. Progress in invasion biology: Predicting invaders. *Trends Ecol. Evol.* 16: 199–204.
- Kottelat M, Freyhof J, 2007. *Handbook of European Freshwater Species*. Cornol, Berlin: Published By Authors.
- Koutrakis E, Perdikaris C, Machino Y, Savvidis G, Margaris N, 2007. Distribution, recent mortalities and conservation measures of crayfish in Hellenic fresh waters. *B. Fr. Peche. Piscic* 385: 25–44.
- Leonardos ID, Kagalou I, Tsoumani M, Economidis PS, 2008a. Fish fauna in a protected Greek lake: Biodiversity, introduced fish species over a 80-year period and their impacts on the ecosystem. *Ecol. Freshw. Fish.* 17: 165–173.
- Leonardos ID, Tsikliras AC, Eleftheriou V, Cladas Y, Kagalou I et al., 2008b. Life history characteristics of an invasive cyprinid fish *C. gibelio* in Chimaditis Lake (northern Greece). *J. Appl. Ichthyol.* 24: 213–217.
- Lindsey CC 1988. Factors controlling meristic variation. *Fish Physiology* 11: 197–274.
- Lovell T 1998. *Nutrition and Feeding of Fish*. New York: Kluwer Academic Publishing.
- NACRES, 2000. *Management Plan: Lakes: Khanchali, Bugdasheni, Madatapa*. Tbilisi, 31 pp; [http://www.nacres.org/pdf/javakheti\\_en.pdf](http://www.nacres.org/pdf/javakheti_en.pdf); Retrieved 01.2013.
- NBSAP-Georgia, 2005. *National Biodiversity Strategy and Action Plan – Georgia*. Tbilisi, pages 106; <http://www.cbd.int/>; Retrieved 02.2013.
- Nei M, Kumar S, 2000. *Molecular Evolution and Phylogenetics*. New York: Oxford University Press.
- Nilsson PA, Bronmark C, Petterson LB, 1995. Benefits of a predator-induced morphology in crucian carp. *Oecologia* 104: 291–296.
- Ninua N, Japoshvili B, 2008. Check List of Fishes of Georgia. *Proc. Inst. Zool.* 23: 163–176.
- Ninua N, Japoshvili B, Bochorishvili V, 2013. *Fishes of Georgia*. Tbilisi: TSIGNI-ERI.
- Parker IM, Simberloff D, Lonsdale WM, Goodell K, Wonham M et al., 1999. Impact: Toward a framework for understanding the ecological effects of invaders. *Biol. Invas.* 1: 3–19
- Peres-Neto PR, Magnan P, 2004. The influence of swimming demand on phenotypic plasticity and morphological integration: A comparison of two polymorphic charr species. *Oecologia* 140: 36–45.
- Perdikaris C, Ergolavou A, Gouva E, Nathanailides C, Chantzaropoulos A, 2012. *Carassius gibelio* in Greece: The dominant naturalized invader of freshwaters. *Rev. Fish Biol. Fish.* 22: 17–27.
- Pimentel RA, 1979. *Morphometrics: The Multivariate Analysis of Morphological Data*. Iowa: Kendall/Hunt.
- Rohlf FJ, 2005. *tpsDig, Digitize Landmarks and Outlines, version 2.05*. Stony Brook: Department of Ecology and Evolution, State University of New York.
- Sadovskii AA, 1930. *Lake Paliastomi and Its Fishery Perspectives*. Moscow: Collection of Works, Seria A, Natural Sciences (In Russian).
- Sakai H, Yamazaki Y, Nazarkin MV, Sideleva VG, Chmylevsky DA et al., 2011. Morphological and mtDNA sequence studies searching for the roots of silver crucian carp *Carassius gibelio*



- (Cyprinidae) from ponds of Sergievka park, Saint Petersburg, Russia. Proc. Zool. Inst. RAS, 315: 352–364.
- Sharvashidze V, 1960. Identification Keys of Fishes of Georgia. Tbilisi: Tsodna (In Georgian).
- Sokal RR, Rohlf FJ, 1995. Biometry: The Principles and Practice of Statistics in Biological Research. New York: Freeman and Company.
- Takada M, Tachihara K, Kon T, Yamamoto G, Iguchi KI et al., 2010. Biogeography and evolution of the *Carassius auratus*-complex in East Asia. BMC Evol. Biol. 10: 7.
- Tamura K, Peterson D, Peterson N, Stecher G, Nei M et al., 2011. MEGA v5: Molecular evolutionary genetics analysis using maximum likelihood, evolutionary distance, and maximum parsimony methods. Mol. Biol. Evol. 28: 2731–2739.
- Toth B, Varkonyi E, Hidas A, Meleg EE, Varadi L, 2005. Genetic analysis of offspring from intra- and interspecific crosses of *Carassius auratus gibelio* by chromosome and RAPD analysis. J. Fish Biol. 66: 784–797.
- Yang B, Chen X, Yang J, 2011. Non-native carp of the genus *Cyprinus* in Lake Xingyun, China, as revealed by morphology and mitochondrial DNA analysis. Biol. Invas. 13: 105–114.
- Vasilieva ED, Vasiliev VP, 2000. On the problem of origin and taxonomic status of the triploid form of gibel carp *C. auratus* (Cyprinidae). Vopr. Ikhtologii 40: 581–592.
- Vetesnik L, Papousek I, Halacka K, Luskova V, Mendel J, 2007. Morphometric and genetic analysis of *Carassius auratus* complex from an artificial wetland in Morava River floodplain, Czech Republic. Fisheries Sci. 73: 817–822.
- Wheeler A, 2000. Status of the crucian carp *Carassius carassius* (L.) in the UK. Fisheries Manag. Ecol. 7: 315–322.
- Wouters J, Janson S, Luskova V, Olsen KH, 2012. Molecular identification of hybrids of the invasive gibel carp *Carassius auratus gibelio* and crucian carp *Carassius carassius* in Swedish waters. J. Fish Biol. 80: 2595–2604.
- Zenetos A, Pancucci-Papadopoulou MA, Zogaris S, Papastergiadou E, Vardakas L et al., 2009. Aquatic alien species in Greece (2009): Tracking sources, patterns and effects on the ecosystem. J. Biol. Res. 12: 135–172.